

بِسْمِ اللَّهِ الرَّحْمَنِ الرَّحِيمِ



# RULEBOOK



From Code To Creativity, We Deliver It All

## Introduction

**Ready to compete with your BOTS ? As the age of robotics & Artificial Intelligence is approaching we need to be prepared for what is Coming !!!!!**

Prepare yourself for an engaging and thrilling event at CUST. Robocust brings the opportunity for every robotics lover to showcase their talents at this Robocust 2025 and compete against the best in the game! The main objective of Robocust is to improve the critical thinking with new and innovative solutions, set of practical activities, implementing new ideas, enlarging people's will for improving and creating better world. Furthermore to prepare the youth in the field of robotics & AI.

**ROBOCUST 2025** contains five sub events along with one workshop:

- 1- Robo Race
- 2- Robo Maze
- 3- Robo War
- 4- Sumo War
- 5- Aero War
- 6- Workshop on Robotics

Robocust 2025 provides you the highest quality practice in education and makes your ideas work. Becoming part of this robotics competition will give you the opportunity to broaden your understanding of the industry and technology, as well as gain familiarity with the content of standards in which you are involved.

Generally ROBOCUST 2025 is divided into two major categories: -

### 1-College Category

### 2- University Category

#### 1- College Category.

In college category all types of schools and colleges can participate, following the rules which are predefined for their respective category.

All colleges and schools can participate in following three themes of ROBOCUST 2025. All students registered with school and colleges can participate. Any team who wants to participate as a private team ( who have no affiliation with any institution should inform the Head Robocust or event head robocust mentioned at the end of document). AGE restriction applies to all categories. Age conditions will be same as applied by school and colleges.

- 1- ROBO RACE (Line follower robotics competition)
- 2- MAZE SOLVER
- 3- Workshop on Robotics

### 2- University Category

## 2-University Category

In University category all types of universities can participate, following the rules which are predefined for their respective category.

All Universities can participate in following three themes of ROBOCUST 2025. All students registered with Universities can participate. Any team who wants to participate as a private team (who have no affiliation with any institution should inform the Head Robocust or event head robocust mentioned at the end of document). AGE restriction applies to all categories. Age conditions will be same as applied by all HEI's

- 1- Robo Race
- 2- Robo Maze
- 3- Robo War
- 4- Sumo War
- 5- Aero War
- 6- Workshop on Robotics

General Rules for both categories are as follow:-

### 1- ROBOWAR

Participants have to use their basic intuitive and creative skills to modify their remote-controlled cars into full-on battle machines (Battlebot). During the course of RoboWars, the participant's creations will be put through stringent tests/events that will require the participants to push their Battle bots to their absolute limits.

### Arena Specifications

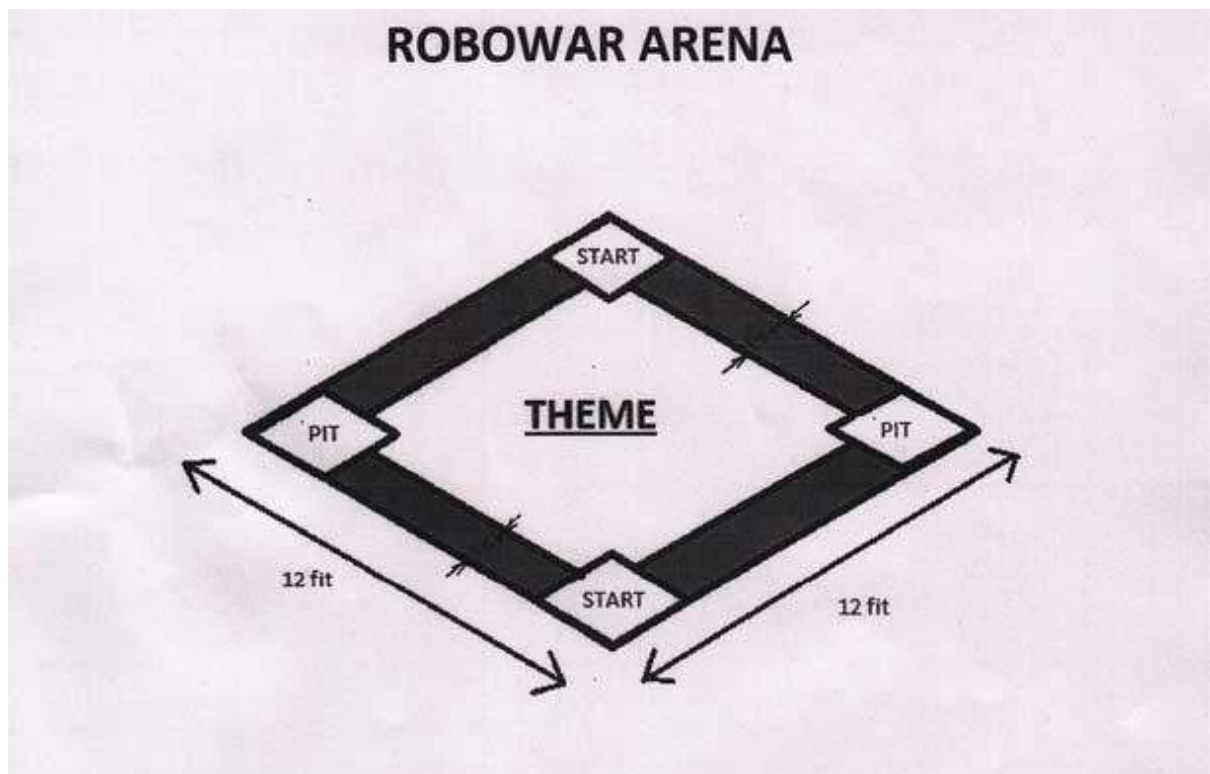

## Rules

- There will be 4 members per team
- Arena will be a simple field with PITS as shown above.
- Robot falling the PIT might stuck in it and if not be able to move for 1 minute then it will be disqualified.
- Robots can be remote controlled.
- One robot can be controlled by two persons
- Weapons should not cause danger to the surroundings. It should only be target specific.
- Weapons can only be the 3 times the size of your robot.
- Dimension of the robot should not be greater then 3x3 ft.
- 10 minutes setup time before start of war.
- War will continue until one of the robot stops working.
- 1 minute will be observing time for robot disqualification.
- 2 timeouts of 2 min each can be called during a war round.

## Registration.

Register online at <https://robocust.cust.edu.pk/>

- 2 members per team.
- Registration Fee Rs 2,500/- per team

FORM LINK FOR ROBOWAR:

<https://forms.gle/19nf7WY2gFzwL4js8>

---

## 2- ROBO RACE (Line follower)

New Track for the year 2025 has been engineering to evaluate different kinds of robots made by the engineers and students.

This year the name of the Track is Called the **The-Tunnel** .This track has been engineering to make the robots intersect their path as they will provide hurdle or change in angle /path to ensure the other robot is not hard coded.

Robocust will follow its legacy this year too with a **dual race (signature track of robocust)** Robo Race also called line follower robotics competition is one of the oldest competitions that is used to be held in CUST. In this competition a robot has to follow the line from start to end in a minimum time without going off the line. Previously A LINE FOLLOWER ROBOTICS COMPETITION held in 2019 and 2022,24 in which more than 38 teams participated to show their skills in the field of critical thinking, programming and robotics.

Following are the rules for ROBORACE:-

- 3 Members per team (standard) , could be 4 with extra registration.
- The robot must be completely autonomous once the operator starts it.
- Robot should weigh NOT more than **10kg**
- In addition there are no restrictions on the sensors used by the contestants. The robot can also touch the lines on the ground in order to detect them; however it must not at any point damage the track. If the track gets damaged then the robot will be disqualified. (should be taken seriously as in previous years sensors damaged the track)
- There are restrictions in using readymade kits and modules, although effort put on making the robot is taken into account while judging the robot by the jury.Premade Chinese or any other branded full robotic kits not allowed as robocust encourages self made machine so there should be self made power distribution box, sensors ,motor driver, Wheels , robot base, although premade available separately could be utilized
- **1 Point** will be given on crossing every check point.
- If any robot stops working or if there is a technical fault, then it should be picked up by one of the team members and restart from the start point, as preferred by the team members, this will be counted a retry.
- Maximum three retries are allowed, the minimum time will be counted.
- The jury may stop any robot at any time if they feel that it is performing or about to perform any action that is dangerous or hazardous to people or setup.
- Teams will be given 1 minute for setting up the Robot at the start point.
- Robot can start at the instant when the start signal is given and a whistle is blown.
- Once the Robot moves, team members will not be allowed to touch the Robot

or enter in the Contest Arena. Team member will raise his hand to notify if he wants a retry

- Time will start once the start signal is given and the whistle is blown.
- Time duration for robots is 8 minutes. They can take 3 retries within this time period.
- The robot should not jump over, fly over, climb, scratch, cut, burn, mark, damage, or destroy the walls of the maze.
- Any type of hard coding done in robot at the moment could be penalized.
- NEURAL NETWORK algorithms to train your robot in the live competitive round is allowed.
- Track could be modified on the runtime to give ease to robots to complete the track and to check the hardcode as well.
- Start and Finish Point Could be Vice versa as presented in website/fb/ or rule book , but it will be same for both teams competing at a time.

- **Round 1:** Every year there are two rounds , round 1 is qualifying round which just check the robots that it can track a line and it is time based.
- **Round 2** is check points +time based . the robot with maximum number of check points with minimum time + minimum retries taken will win the match.
- There are 1 to 1 dual race and robots will be judged by the judges in race.
- **Rule of race :** The rule of race is who ever reaches the finish point first wins ( keeping in view rules as mentioned above).
- **Round 2** Round 2 is points based (including rule of race). A robot has to take multiple races to win against multiple bots. The points will be added from previous race.. The final winner will be with most points secured ( keeping in view the rules as mentioned above).
- **Draws :** Draws will be conducted to schedule the matches of all teams. (At a time 2 teams will race on track)
- **Construction :** Pre made kits, robots with premade module kits, robots with premade boards i-e sensor boards, H-bridge, controller boards, robotic base. All will be judge on the basis of logic and their hardwork. Robots with pcb and vero board which will be self made will be given preference on the basis of self made design. Robocust encourages participant to build all modules by them selves rather purchasing pre made modules. In any case all types of robots will be allowed. Marking with points will be judged by judges and marks can be given to robot with self made modules. All other race rules on track remain as mentioned.

## A- ROBOT Specifications

### 1- *LEGO MINDSTORMS kits for school & college category*

1. NXT 2.0 or NXT 2.1 or Ev3
2. RCX Brain
3. Spike prime
4. Programmable premade hardware robotics kits for kids (Schools only) are also allowed.
5. Logic Based Robots are allowed
6. Dimension of robot=30cm x 30cm x 30cm (LxWxH)
7. 10kg weight is allowed maximum
8. Other than mentioned above premade Chinese or branded kits which contain all in one chip are not allowed for college. Self-made robot is encouraged.

### 2- *Microcontroller or microcontroller kits for university category*

1. Only programmable microcontrollers are allowed (Arduino, pic, atmel, raspberry pi , ESP32 STM32 etc)
2. Logic Based Robots are allowed
3. Premade sensors are also allowed
4. Dimension of robot=30cm x 30cm x 30cm (LxWxH)
5. 10Kg is the wight that is allowed maximum

# Track A-

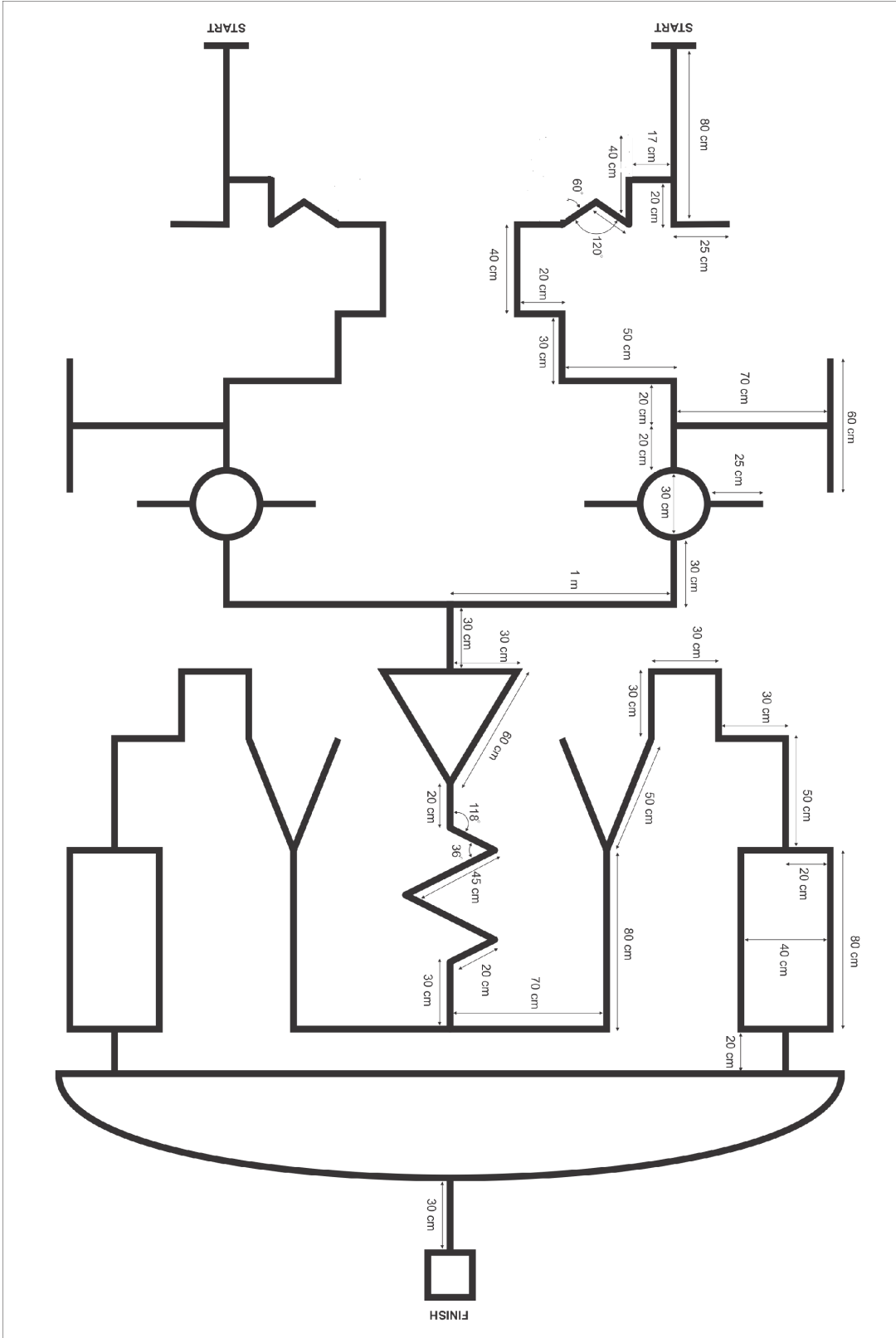



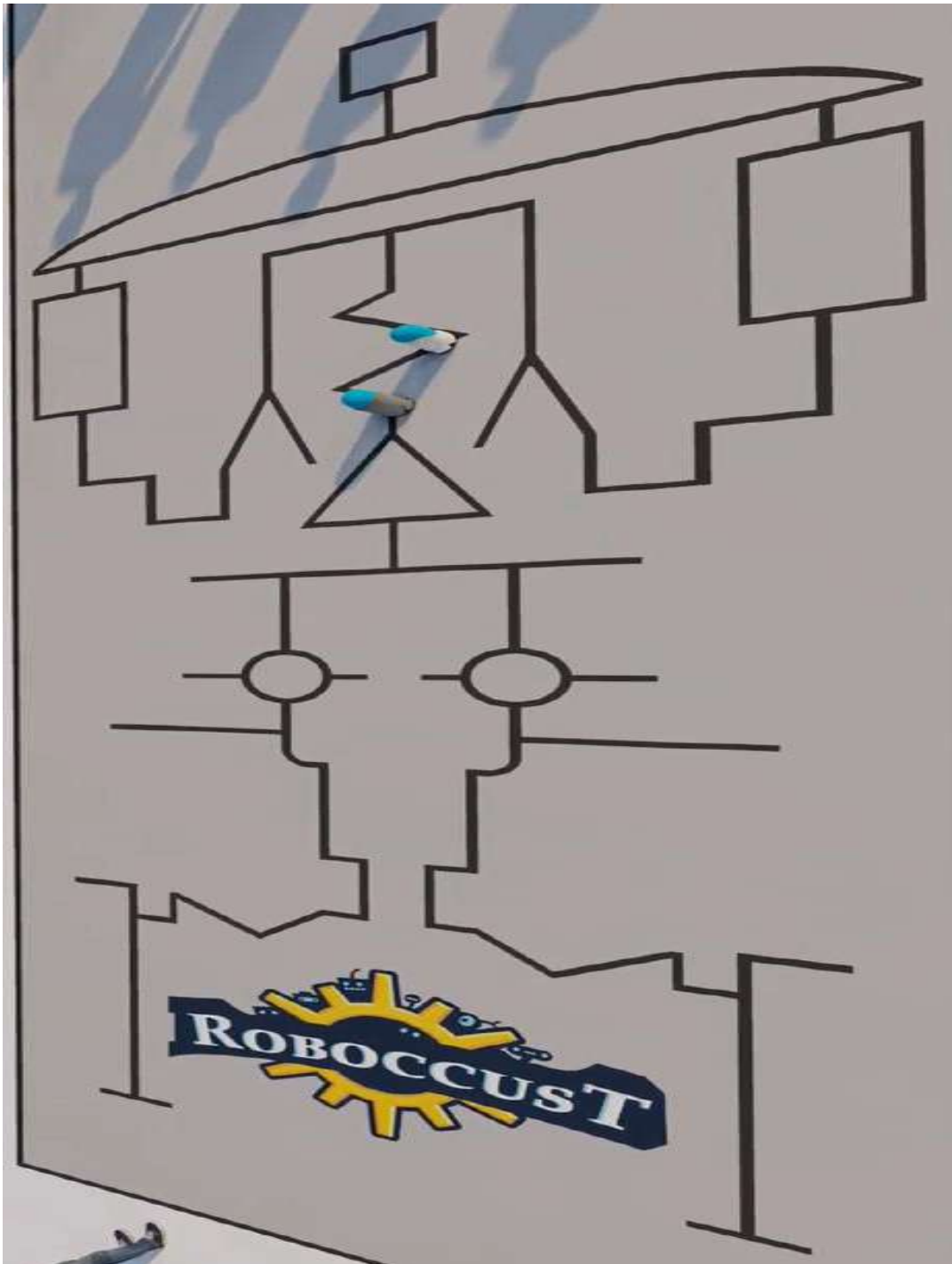

*Robocust 24 , robo race track “ The Intersection” -Total Track size is 28x10 ft , lengths of lines will not be disclosed to avoid hard coding, where as pdf file will be shared on website*

- The track is called dual race track. Two teams will compete with each other on the same time. Robot which finishes first wins the round. If a robot does not reach the end then it will be decided on the checkpoints mentioned on the track and on the basis of the rules mentioned above.
- **RED line**/hyphen are check points - equal marks (1 point each)
- Field Dimensions: 28ft x 10ft
- The line width is 3cm and is made of Black Binding tape with white background.
- Line width=3cm
- Track could be modified in case of all the robots not completing the track
- Robots finishing in equal time or not completing the track, will be decided by the check POINTS

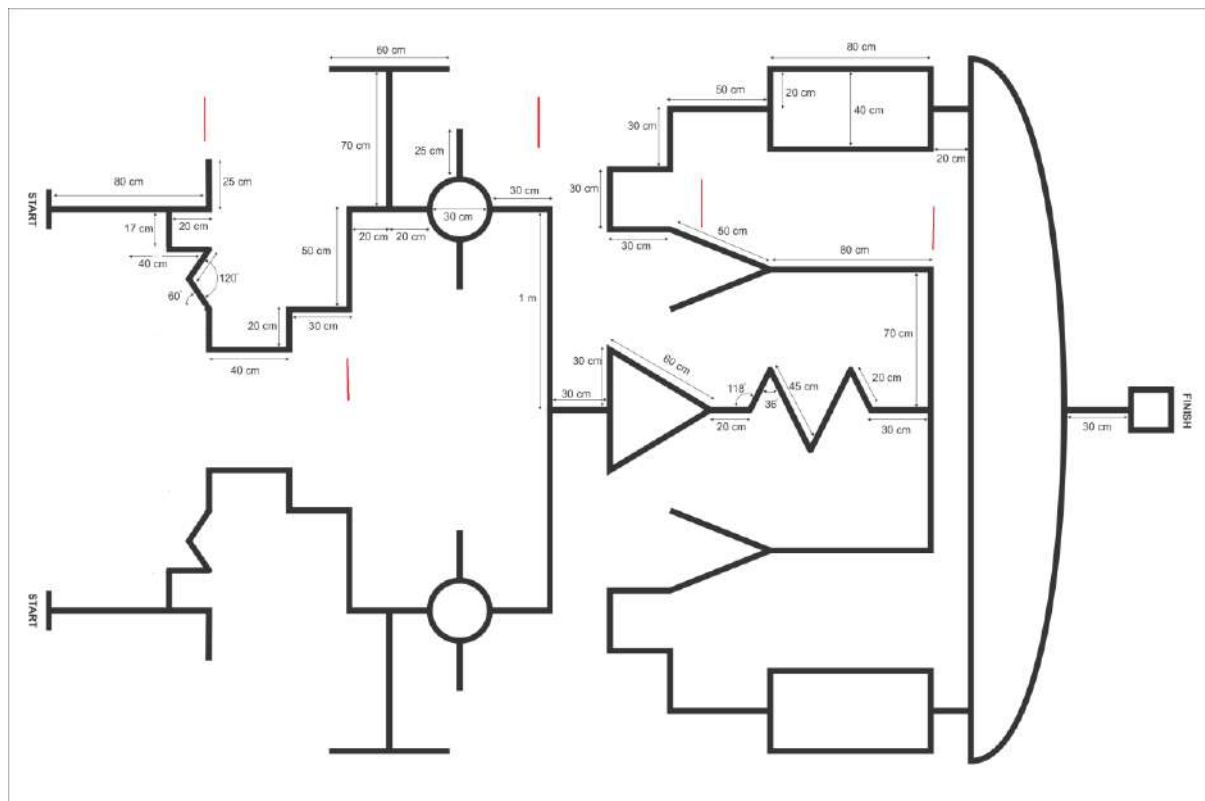

## **Registration.**

Register online at <https://robocust.cust.edu.pk/>

Or go on the link: <https://forms.gle/B9uiZjcmUaNqyXZAA>

- 3 members per team. (minimum 1 member per team)
- Registration Fee Rs 2500/- per team

In case of 4 members registration fee is 3000/-

### ***PATRON SEEK AND HEAD ROBOCUST 2025***

**Account Detail:** Name: Muhammad Waleed Farooq

#### **Bank Details**

Account Name: Muhammad Waleed Farooq

Branch Code: 0737

Branch Name: Afshan Colony

Bank Name: Allied Bank Limited

Account Number: 0010035601250023

IBAN: PK80ABPA0010035601250023

**Easypaisa:**03315381387

( Write your transaction ID received after sending the amount in online registration form)

Bring the printout of transaction on the day of competition.

### 3- MAZE SOLVER

Robomaze is a competition in which the robot navigates out of the maze in the quickest possible time and collects maximum possible points from the designated starting and end points.

#### Track

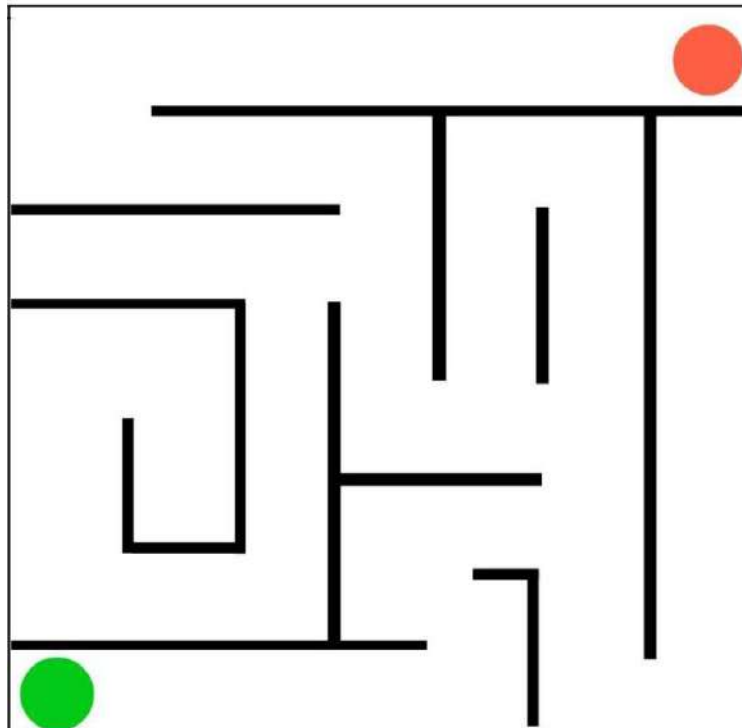

#### Track dimensions:

All the numbers are in ft.

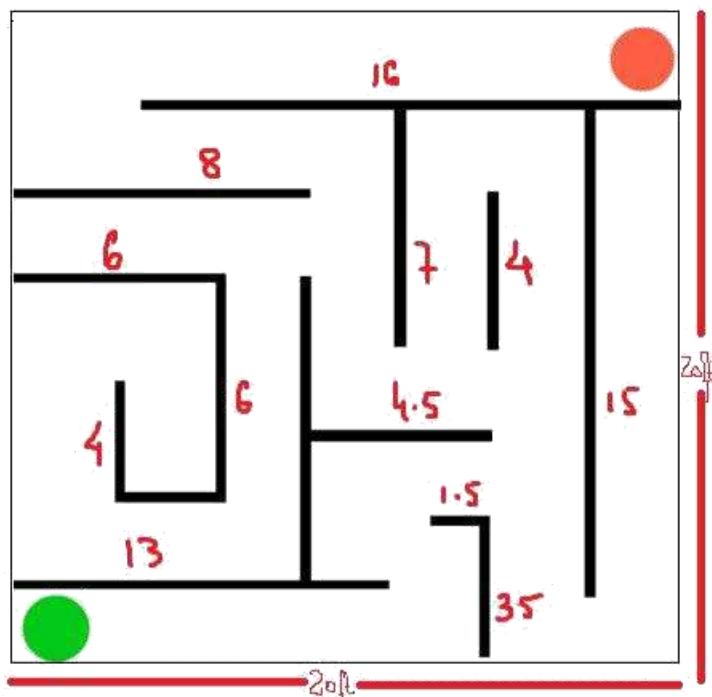

## Rules

- 10 minutes setup time will be given before the start of the competition
- There will be 3 retries in round 1.
- Robot who finishes the maze in minimum time will be advanced.
- There will be total of 3 rounds. Half of the teams will be disqualified per round.
- 15 minutes will be given to each team to run their robot in the track !
- The height of the wall will be 6-8 inches. It will be 6 inches (minimum) .
- The wall will be made of white wooden sheets of half inch width

## Registration.

Register online at <https://robocust.cust.edu.pk/>

OR GO AT : <https://forms.gle/B9uiZjcmUaNqyXZAA>

- 3 members per team. (minimum 1 member per team)
- Registration Fee Rs 2500 /- per team
- Incase of 4 members registration fee is 3000/- maximum 4 members allowed

#### 4- SUMO-War

The robot should be remote controlled or students can make mobile App controlled Sumo Robots and compete against each other to win a seeded tournament (see **Figure below**) like a contest. Similar to traditional Sumo wrestling the contesting robots will try to push each other off the ring (Dohyo). Teams will be randomly selected to compete against each other and winning teams from each round will qualify for the next round.

#### Rules

- 10 minutes setup time will be given before the start of the competition
- There will be 3 retries in round 1.
- Robot size should be **15x15 cm**, maximum weight could be upto 4kg.
- All other damaging rules apply.

#### Registration

- 3 members per team. (minimum 1 member per team)
- Registration Fee Rs 2500 /- per team

In case of 4 members 3000 per team

Register online at <https://robocust.cust.edu.pk/>

OR GO AT : <https://forms.gle/B9uiZjcmUaNqyXZAA>

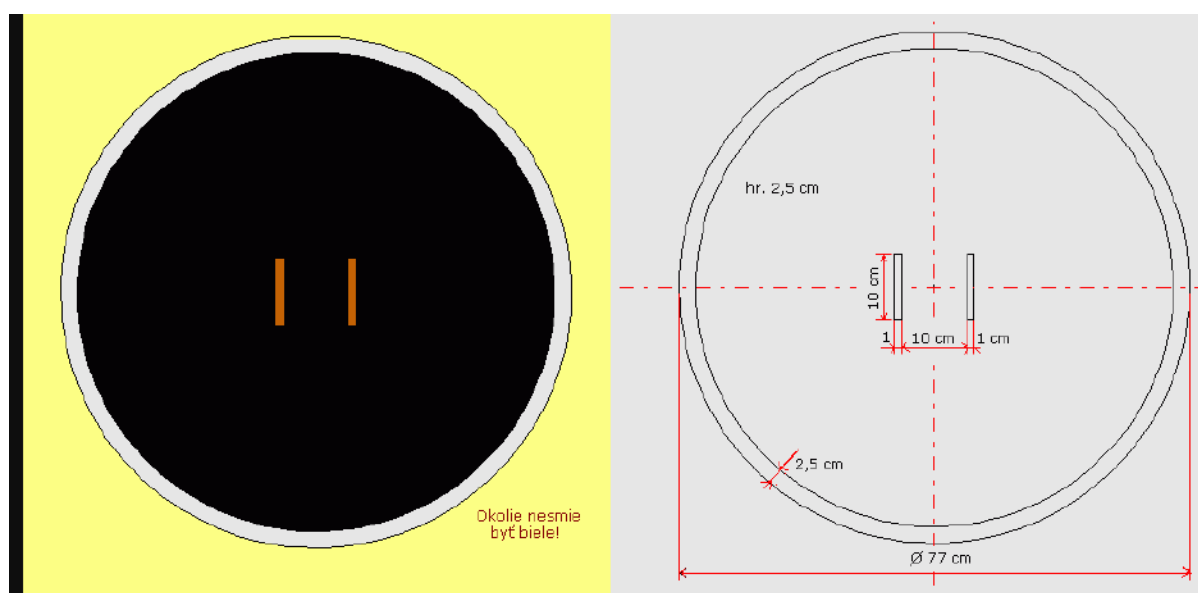

## 5- Aero-War

Simple Drones and RC Plane race to fly and show case their skills. Skills will be assessed on the basis of their structure, how they are made and how they can fly.

1-RC Plane, Take off , landing, rollover, any other move

2-Drone take off , landing, roll overs, any other move.

In case of multiple equipment in same category might have a race of a lap or two to be assessed.

### Rules

- 10 minutes setup time will be given before the start of the competition
- There will be 3 retries in round 1.
- All other damaging rules apply.

### Registration

- 3 members per team. (minimum 1 member per team)
- Registration Fee Rs 2500 /- per team

In case of 4 members 3000 per team

Register online at <https://robocust.cust.edu.pk/>

OR GO AT : <https://forms.gle/B9uiZjcmUaNqyXZAA>

### General Instructions

1. Both an individual and a team can register for the maze solving competition.
2. A team may consist of up to five people.but they to submit 1000/ person more.

### Changes and cancellations in the rules

- Rules could be modified to give ease to robots so they can complete the task. Rules will be applied for all teams.
- The tracks will be available for practice on 11 February 2025 and competition will held on **15th February 2025**
- Last date of registration is **13 February 2025**
- Same robot can be used in different themes. Half registration should be paid in order to participate in other theme using same robot.
- All categories will have handsome amount of winning prizes along with souvenir, shields and winning/participation certificates.

- Prize could vary according to number of registrations.
- Please register within given time. Than you

Sr#	Name	Designation	Contact number
1	Engr.Muhammad Waleed Farooq	Associate Lecturer/PATRON SEEK/ Founder ROBOCUST 2025/Registration Head	03315381387
2	Daniyal Asgher	Robocust Coordinator / Founder Hexofarm	0307-5675598
3	Wahab Tanveer	President SEEK Society	0345-5769816
4	Alisbha	Robocust Head and VP SEEK	
5	Zaryab	/Technical Support for Tracks	0308-8465538

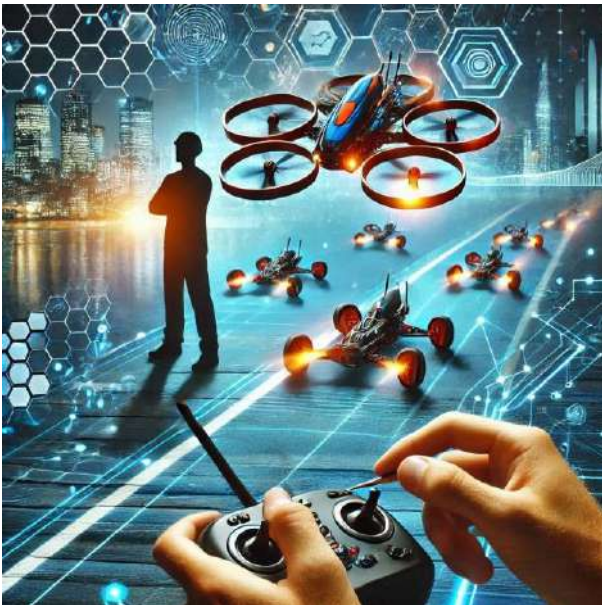

**AERO WAR: Drone race & RC Plane**



## Workshop on Robotics

A three-day workshop will be organized for both College category & University category to train and teach students. In these three days the participant will be given detail lecture and practical tutorial on the robotics. A participant will be able to build a robot in three days and can participate in the competition after Completing the workshop.

**Workshop dates:** 9-10 FEB 2025 ,4-7:30 PM OR 5-8 PM , Digital Electronics Lab CUST

**Last Registration Date:** 15 FEBUARY 2025 for Robocust competition

**Register online at :** [www.robocust.cust.edu.pk](http://www.robocust.cust.edu.pk)

**Or directly register on following links**

>-----Workshop Registrations

Register online at <https://robocust.cust.edu.pk/>

OR GO AT : <https://forms.gle/B9uiZjcmUaNqyXZAA>

### Registration.

Or at <https://robocust.cust.edu.pk/>

### ***PATRON SEEK AND HEAD ROBOCUST 2025***

**Account Detail:** Name: Muhammad Waleed Farooq

### **Bank Details**

Account Name: Muhammad Waleed Farooq

Bank Name: Allied Bank Limited

Branch Code: 0737

Branch Name: Afshan Colony

Account Number: 0010035601250023

IBAN: PK80ABPA0010035601250023

**Easypaisa:**03315381387

Easypaisa:03315381387

( Write your transaction ID received after sending the amount in online registration form)



AERO WAR

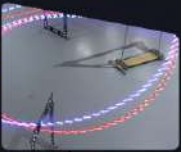

SUMO WA



SCAN THE QR CODE



FOR REGISTRATION

03315381387

farooqwaleed@yahoo.com

For more information visit

[robocust.cust.edu.pk/](http://robocust.cust.edu.pk/)



# ROBOCUST 2025



ROBO RACE



ROBO MAZE



ROBO WAR

15 January 2025

CUST, Islamabad





Capital University Of Science & Technology, Islamabad

# ROBOCUST

# 2025

## MAJOR THEMES OF COMPETITION

ROBO RACE

ROBO MAZE

ROBO WAR

SUMO WAR

AERO WAR

BUILD YOUR OWN ROBOT

TAKE "WORKSHOP ON ROBOTICS"



## 3 Workshop on Robotics

Venue: B Block Digital electronics lab  
9-10 February 2025

## Registration Robotics Competition

15 February 2025

CONTACT NOW

Patron ROBOCUST

03315381387

farooqwaleed@yahoo.com

